

# HEAT SIPHON® Installer

## Installer Section Contents

<b>1.0 Receiving Shipment</b> .....	<b>2</b>
1.1 MOVING & HANDLING Precautions .....	3
<b>2.0 Planning Installation</b> .....	<b>5</b>
2.1 Physical Location, .....	5
2.2 Distance From The Pool.....	6
2.3 Pool Piping Required.....	6
2.4 Electrical Power Required.....	8
2.4.1 Electrical Hookup on Unit.....	8
2.4.2 Wiring Location .....	9
2.4.3 Code Requirements.....	9
2.4.4 Wire Size.....	9
2.4.5 Breaker Size .....	10
2.4.6 GFI Protection.....	10
2.4.7 Electrical Disconnect Switch .....	10
2.4.8 Electrical Bonding Requirements.....	11
2.5 Special Installations .....	11
2.5.1 Multiple Units .....	11
2.5.2 Indoor Pools.....	13
<b>3.0 Completing Installation</b> .....	<b>15</b>
3.1 Tools / Materials Required.....	15
3.2 Optional Tools/ Materials .....	15
3.3 Helpful Hints.....	15
3.4 Final Plumbing into Pool or Spa.....	16
3.5 Final Wiring to the Power Line .....	17
<b>4.0 Initial Start-up</b> .....	<b>18</b>
4.1 Initial Performance Checks.....	18
4.2 Adjustment of the Water Pressure Switch .....	19
Figure 4.1 - Water Pressure Switch Adjustment Knob .....	19
Figure 4.2 - Water Pressure Switch Location in Control Box.....	20

# HEAT SIPHON® Technical Manual

## 1.0 Receiving Shipment

NOTICE: ALL Shipments by the factory are made F.O.B.. Latrobe, PA.. As such, the buyer (dealer) takes possession of the Heat Siphon® the minute it leaves the factory loading dock.

United States ThermoAmp, Inc. is NOT responsible for any shipping damage occurring in transit. THE FREIGHT HAULER IS RESPONSIBLE FOR ALL FREIGHT DAMAGE AND ALL DAMAGE CLAIMS MUST BE SETTLED DIRECTLY WITH THE FREIGHT HAULER. The factory will assist you in settling claims wherever possible but YOU MUST DEAL DIRECTLY WITH THE SHIPPER TO RESOLVE ALL FREIGHT DAMAGE.

**IMPORTANT.- IF YOU RECEIVE A DAMAGED HEAT SIPHON® NOTIFY THE CARRIER IMMEDIATELY (THAT MEANS THE CARRIER'S OFFICE, NOT THE DRIVER)**

**CAUTION: A unit which has been dropped will have internal damage which is not apparent from the outside of the carton. If in doubt unpack the unit in presence of the shipper at the time of delivery. Puncture marks and oil stains on the box are indicative of a ruptured and leaking sealed refrigeration system. AND SHIPMENT SHOULD BE REFUSED.**

Heat Siphon® is designed and packaged to ensure safe arrival even with individual shipments, however, if Heat Siphon® is tailgated or dropped, the damage may not be visible from outside the box and if you accept shipment from the trucking company, any subsequent claims of concealed damage will be refused by the freight hauler.

Although unattractive, minor dents in the aluminum evaporator fins won't adversely affect Heat Siphon® performance, we suggest that you make note of ANY damages on the Bill of Lading BEFORE signing for receipt. Damaged fins can be "combed" straight, if not severely smashed, with a "fin comb" commonly carried by most refrigeration repairmen. Black acrylic enamel spray paint can also be used to repair any cosmetic damage.

### 1.1 MOVING & HANDLING Precautions

If only a few simple handling rules are followed, Heat Siphon® can be moved virtually anywhere with no problems:

1. DO NOT DROP OR TAILGATE THE HEAT SIPHON .

# HEAT SIPHON® Installer

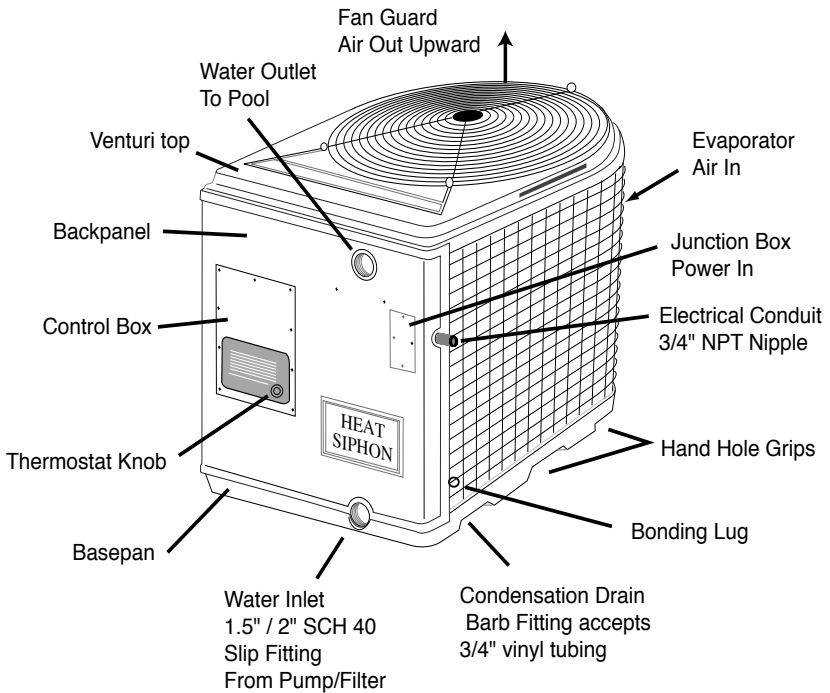

2. DO NOT LAY THE UNIT ON ITS SIDE OR UPSIDE DOWN.

3. DO NOT LIFT THE HEAT SIPHON® BY ITS TOP / VENTURI - USE HAND HOLES IN BASE.

Use a fork truck, roller conveyor or an inclined plane to unload the Heat Siphon® carton. Although the special PVC plastic used in the HEAT SIPHON® cabinet is extremely tough and more than adequate for shipment even in cold weather, it will probably break or crack if dropped from a truck tailgate.

Usually damage will be in one of three places:

1. Where the 25 pound control panel attaches to the base pan;
2. Where the 20 pound fan motor attaches to the top;
3. Where the 75 to 120 pound compressor fastens to the base pan.

Cracked plastic cabinet parts may or may not need to be replaced but can be expensive to replace if all the components need to be removed and remounted on a new cabinet part.

Other freight damage - bending of the fan motor mounting bracket that causes the fan

# HEAT SIPHON® Technical Manual

blade to rub or rupturing of a copper refrigerant tube. Usually this can be repaired by a local refrigeration service center with minimal difficulty.

If tilted too far from the vertical position, the weight of the compressor can bend or break tubing or even break or crack the plastic base pan at the compressor mount.

The top venturi/fan assembly is fastened to the unit using three stainless steel screws which are anchored to sheet metal flanges. This is more than adequate for ensuring a firm vibration-free assembly to the Heat Siphon® body, but these mounting screws are not designed to support the entire weight of the unit. Once out of the box, the Heat Siphon® should be lifted by the base pan only. Hand holes have been molded into the basepan for easier handling.

# HEAT SIPHON® Installer

## 2.0 Planning Installation

**IMPORTANT - READ THIS ENTIRE SECTION COMPLETELY THRU BEFORE YOU BEGIN TO INSTALL HEAT SIPHON®:**

### 2.1 Physical Location

Normally, the pool piping layout and the electrical supply will dictate the general location of the Heat Siphon®. In addition, the following guideline should be adhered to when picking the location:

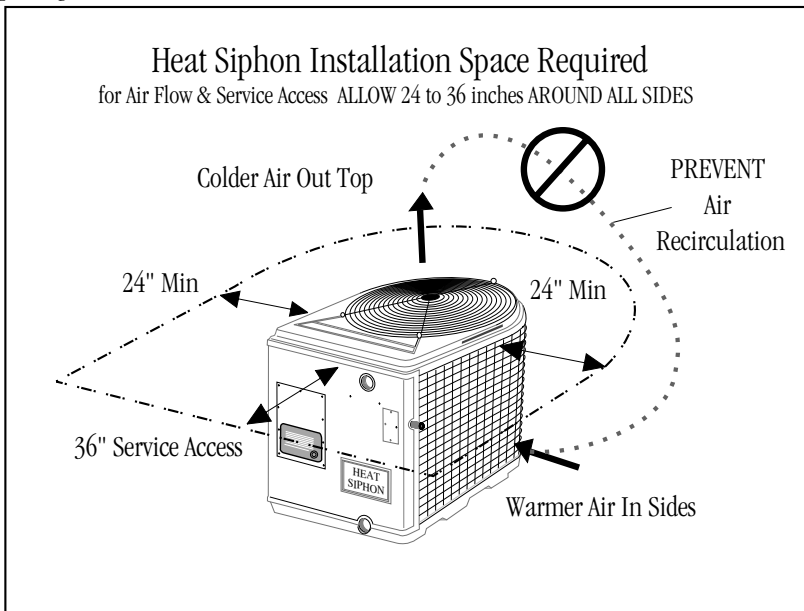

1. Allow 24 to 36 inches of open area all around the Heat Siphon® for good air circulation and service access. Avoid any overhangs or structures which could cause exhaust air to recirculate from the top of the unit back into the sides.
2. Ensure the Heat Siphon® will be level when in place to aid in condensation and rain water drainage. Sand or a cement slab will provide an inexpensive attractive easy to level mounting base with good drainage.
3. To minimize noise point the flat side of the unit with Heat Siphon® trademark impression toward areas people will frequent. The plastic

# HEAT SIPHON® Technical Manual

front panel reduces the already low operating sound level even further in that direction by absorbing compressor noise which the evaporator side does less effectively. Heat Siphon's noise dampened plastic base pan ensures extremely quiet operation.

## 2.2 Distance From The Pool

Normally, the pool pump and Heat Siphon® are installed close together and within 25 feet of the pool. The longer the distance from the pool, the more heat loss from the piping. Since most of the time the piping is buried, the heat loss is minimal for runs of up to 50 feet (50 feet to and from the pump = 100 feet total) unless the ground is wet or the water table is high. A very rough estimate of heat loss per 100 feet of piping is 2500 BTU/Hr. for every 10°F difference in temperature between the pool water and the ground surrounding the pipe, which translates to about a 3% to 5% increase in run time.

## 2.3 Pool Piping Required.

The dual socket water ports allow you to glue either 1.5 inch or 2 inch (with a standard 2" PVC coupling) schedule 40 PVC pipe directly into the heat exchanger. No metal heat sink piping is required.

**IMPORTANT: ALLOW AT LEAST 6 INCHES OF STRAIGHT PIPE BETWEEN THE HEAT EXCHANGER AND ANY COUPLING UNIONS OR ELBOWS TO ALLOW BACKPANEL REMOVAL FOR SERVICING .**

# HEAT SIPHON® Installer

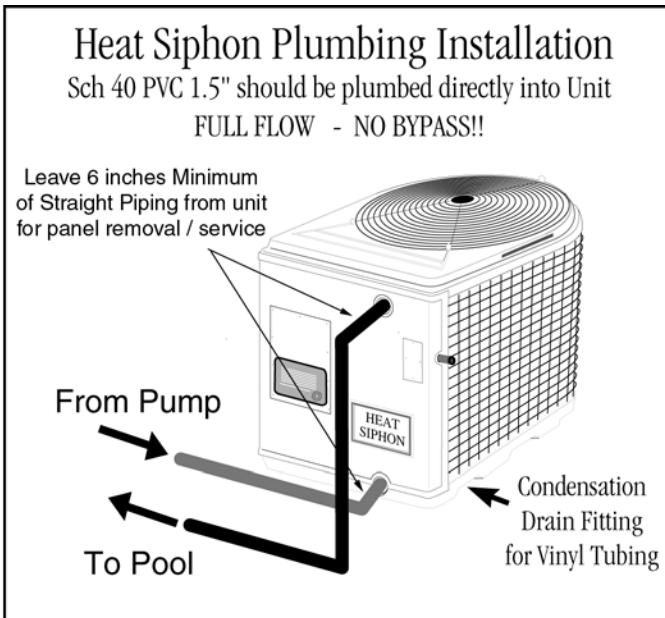

**CAUTION: DO NOT USE ANY BYPASS PIPING. HEAT SIPHON® REQUIRES FULL FLOW FROM 25 TO 80 GPM. INSTALLING A BYPASS MAY CAUSE SHORT CYCLING DAMAGE AND WILL VOID THE WARRANTY.**

**NOTE. If the VERTICAL DISTANCE between the pool water level and the Heat Siphon® is excessive (below or above 5 feet) and your Heat Siphon®'s flow switch is a pressure sensing type, it may require adjustment at installation (see section 4.2 ).**

# HEAT SIPHON® Technical Manual

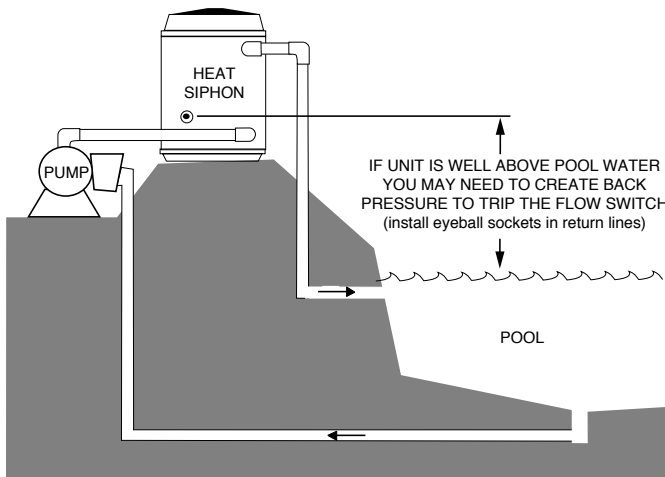
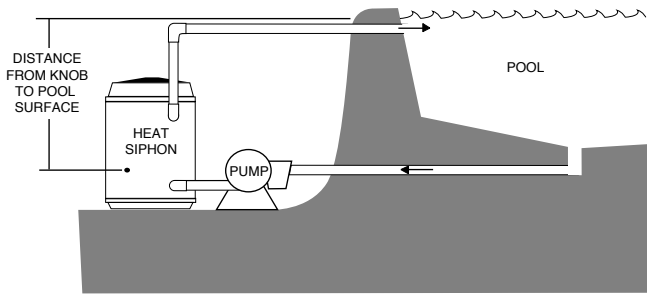

Heat Siphon's exclusive FULL FLOW Titanium heat exchanger has a minimal pressure drop and requires NO SPECIAL PLUMBING arrangement. It should be considered as just another length of PVC pipe in your pool filtration system.

**LOCATION:** Connect Heat Siphon® in the pool pump discharge (return) line DOWNSTREAM of all filters and pool pumps, and UPSTREAM of any electrator chlorinators or chemical pumps.

**SIZE:** All Heat Siphon®s have 1.5" x 2" fittings for connection to the pool or spa filtration piping which will accept 1.5" schedule 40 PVC pipe directly or 2" SCH 40 PVC pipe with a 2" PVC coupling. The in-line water pressure drop produced by Heat Siphon is less than 1.5 psi at 30 GPM.

## 2.4 Electrical Power Required.



# HEAT SIPHON® Installer

**WARNING: DO NOT ATTEMPT TO COMPLETE ANY ELECTRICAL INSTALLATION OR SUPPLY CIRCUIT WIRING UNLESS YOU ARE QUALIFIED AND EXPERIENCED IN THE FIELD. HEAT SIPHON® REQUIRES HIGH VOLTAGE POWER WIRING WHICH SHOULD BE INSTALLED IN ACCORDANCE WITH ALL ELECTRICAL CODES, ONLY BY QUALIFIED DEALERS WITH PROPER TRAINING AND LICENSES OR A LICENSED PROFESSIONAL ELECTRICIAN.**

## 2.4.1 Electrical Hookup on Unit

Connect the proper size wire (including grounding) by electrical conduit, UF cable or other suitable means (as permitted by local electrical codes) to a dedicated AC power supply branch circuit equipped with the proper circuit breaker, disconnect or time delay fuse protection.

## 2.4.2 Wiring Location

Heat Siphon® has a separate molded-in junction box on the right side of the back panel with a standard electrical conduit nipple already in place. Just remove four screws and the small cover, feed your supply lines in through the conduit nipple and wire-nut the electric supply wires to the three pigtails already in the junction box. (Four or five wires if three phase).

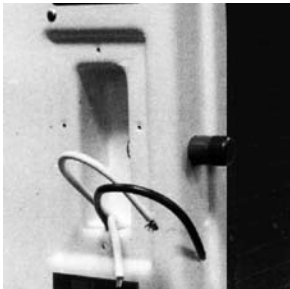

No other pool heater is as easy to wire.

## 2.4.3 Code Requirements

The following are National Electrical Code (Article 339-3 and 680-10) requirements regarding burial of the electric supply wires, and are provided here FOR GUIDANCE ONLY

**NOTE: LOCAL CODES SUPERCEDE AND MAY VARY FROM THESE REQUIREMENTS**

1. All supply cable should be at least 5 feet horizontally from the pool wall unless it is in a corrosion resistant metallic, or nonmetallic raceway system and must be buried at least the following minimum depth:

Wiring System	Min. Burial Depth
(a) Direct Burial Cable	24 inches
(b) Rigid Nonmetallic Conduit	18 inches

# HEAT SIPHON® Technical Manual

(approved for direct burial w/o concrete encasement)

(c) Rigid Metal Conduit 6 inches

(d) Other Approved Raceways 18 inches

2. UF cable (approved for direct burial ) is permitted for supply runs from the circuit breaker to the Heat Siphon®. UF cable must be protected from damage where it is exposed (not buried) between the ground and the breaker box or Heat Siphon® junction box using suitable means.

3. Use copper conductors (wire) only. Aluminum is unsuitable for pool equipment service.

## 2.4.4 Wire Size

The following table suggests supply circuit wire size for type UF or TW conductors assuming a maximum 3 volt line loss is desired for the basic Heat Siphon® models noted. The wire sizes are SUGGESTED ONLY based on the National Electrical Code Standards UNDER NORMAL CONDITIONS ONLY and are NOT intended to supersede local codes or other restrictions that may apply. All local electrical and building codes as well as the National Electrical Code (Articles 300 & 310) should be consulted for additional guidance.

### SUGGESTED WIRE SIZES (buried / in air)

Model (Volts/Hz/Phase)	For Length of Run		
	50 ft.	75 ft.	100 ft.
2.25 HP (208-230v /60/1)	#14 / #14	#12 / #12	#10 / #10
3.25 HP (208-230 v/60/1)	#12 / #10	#10 / #10	#8 / #8
5.0 HP (208-230v/60/1)	#8 / #6 <sup>(a)</sup>	#8/#6	#6 / #6
3.25 HPX(44OV/50-60/3)	#14 / #14	#14 / #14	#14 / #14

(a) NOTE: For 5.0HP models if THWN or TWN conductors are used in conduit and length of run is 50 feet or less, #10 AWG size is suggested if buried and #8 is suggested if conduit is in free air.

If your model is not listed or if you have special conditions, are using wire other than type TW or UF, or a nonstandard supply wiring, see the nameplate on your unit for minimum circuit ampacity and consult an electrician.

**CAUTION - SEE NAMEPLATE ON YOUR HEAT SIPHON® FOR ACTUAL CIRCUIT AMPACITY REQUIRED.**

## 2.4.5 Breaker Size

The supply circuit breaker or fuse should be equal in AMPERAGE rating to the HEAT SIPHON® NAMEPLATE MINIMUM CIRCUIT AMPACITY.

# HEAT SIPHON® Installer

## 2.4.6 GFI Protection

Where possible Ground Fault Interruption (GFI) circuit breakers are strongly recommended at the main power supply for electrical equipment in the pool system. This is one low cost insurance policy which virtually eliminates shock hazard as well as equipment damage due to ground fault. Standard plug-in circuit breakers with GFI protection are readily available.

## 2.4.7 Electrical Disconnect Switch

Article 440-14 of the National Electrical Code, which applies to Air Conditioning and Refrigerating equipment, requires that a disconnect means (circuit breaker, fused or unfused switch) *"be located within sight and readily accessible from "* the subject equipment. This means that if the circuit breaker box which supplies the Heat Siphon® is not within sight of the Heat Siphon®, you may be required to install a waterproof disconnect switch/box at or near (within sight of) the installed unit to meet the National Electrical Code. This is a common practice on commercial and residential air conditioners and heat pumps. It prevents someone from remotely energizing unattended equipment or turning on power to a unit while the unit is being serviced, which can SAVE LIVES. It also saves a serviceman time by eliminating walking to and from a remote breaker.

### SIZING THE DISCONNECT SWITCH

Article 440-12 of the National Electrical Code, requires that any Disconnecting switch be rated capable of interrupting at least the total of all nameplate locked rotor current ratings (including fan motors and compressor motors)

## 2.4.8 Electrical Bonding Requirements

Just like all other electrical pool equipment, Heat Siphon® must be bonded (local earth grounding) and usually can simply be tied into the existing bonding circuit with the pool pump etc..

**NOTE: Electrical Bonding to a local earth ground (separate from power supply grounding) through a copper conductor and to any other pool or spa system electrical equipment is required by Article 680 of the National Electrical Code.**

Location - Heat Siphon® has a standard copper bonding lug located on the right side of the unit facing the back panel. (See illustration at the beginning of this Installer Section) This set screw type lug accepts standard #8 solid copper wire. The copper wire should be connected to the bonding circuit of your other pool equipment.

Size - A solid copper conductor, insulated, covered, or bare, not smaller than No. 8 (8.4 mm sq.) - 1981 Nat'l. Electric Code Art. 680-22(b)

# HEAT SIPHON® Technical Manual

## 2.5 Special Installations

### 2.5.1 Multiple Units

If connecting more than one Heat Siphon® on larger pools, the following applies in addition to the SPACE requirements for single units:

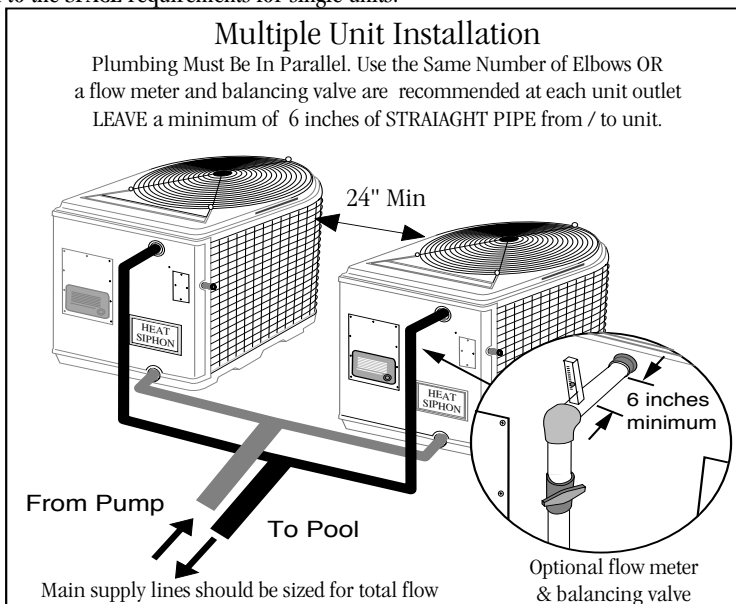

(a) Feed all Heat Siphon's from the same line (PUT THEM IN PARALLEL) and tie all of their water outlets together. ENSURE EACH UNIT RECEIVES AT LEAST 25-30 GPM

(b) If piping (number of elbows and bends) are not identical to each unit then install a flow meter, PVC couplings and shut off valves in each Heat Siphon® 's water line to permit balancing the flow equally between units and to facilitate service and removal if required without shutdown of the pool pumps.

**CAUTION: IN A MULTIPLE UNIT INSTALLATION DO NOT CONNECT THE WATER OUTLET OF ONE HEAT SIPHON® TO THE WATER INLET OF THE NEXT HEAT SIPHON®**

This will create two problems:

# HEAT SIPHON® Installer

- (1) Series plumbing makes it impossible to correctly set the 2nd unit's thermostat-

The water leaving the first unit will be several degrees warmer than the pool. Thus the second unit's thermostat will need to be set several degrees higher than the desired pool temperature before it will turn on and it will cause cycling as the first unit turns off and on. If both thermostats are set the same then the second unit will only run when the pool is colder than the heat rise produced by the first Heat Siphon®.

- (2) Series plumbing reduces efficiency of each Heat Siphon® downstream. -

Warmer water removes less heat from the Heat Siphon's heat exchanger and requires the compressor to work harder. The highest efficiency is achieved by feeding the coldest water to each unit (parallel piping does just that)

## 2.5.2 Indoor Pools

Heating an Indoor pool creates three problems:

- first - the pool water must be heated,
- second - the humidity is increased and the room must be dehumidified,
- third - in winter the room air must be heated.

Most of the heat lost from an indoor pool is a result of evaporation where the room temperature is not increased but rather the room air becomes more humid, creating a condensation problem.

A dehumidifier cools the air down to condense the moisture out, and then reheats the air back to room temperature. The heat it extracts from the air is equal to the heat it puts back into the air except for a small amount of excess heat converted from the electricity it consumes thus there is not enough heat to also reheat the pool water.

Gas pool heaters will heat the pool but provide no dehumidification and still require the room to be heated separately.

Indoor installations of Heat Siphon® not only heat the pool, but provide the added benefit of dehumidification of the pool room. When the Heat Siphon® cools down the room air to extract heat out of it, the moisture in the air condenses on the cold evaporator, thus drying the air. But this requires the room air to be reheated and if the room is small the Heat Siphon® may over cool the air and not operate very efficiently or it may require a fairly large space heater.

If the room is large relative to the pool, there is usually sufficient heat in the air to keep the pool heated, BUT a separate heat source must still be installed for the room air.

# HEAT SIPHON® Technical Manual

Since there is no wind the heat loss from the pool is significantly less than an outdoor pool. If a cover is used on the pool, both the humidity and the heat loss will be greatly reduced to the point where run times of only a few hours per day will maintain pool temperature.

**NOTE - In any case your dealer should consult the Factory before planning any indoor pool Heat Siphon® Installation and make sure there is enough air volume and an adequate source of space heat to overcome the cooling effect.**

# HEAT SIPHON® Installer

## 3.0 Completing Installation

Assuming you have picked the best location and orientation and the necessary amperage electrical power supply and bonding circuits are in place, the only work remaining to complete the installation is final wiring and plumbing of the Heat Siphon®.

### 3.1 Tools / Materials Required

The following is a suggested list of tools and materials normally required for Heat Siphon® installation. Additional tools and materials may also be required by unique or extraordinary pool sites:

- PVC pipe & fittings
- Hacksaw
- Pliers
- Circuit breaker with GFI
- Wire of size length and insulation required to meet local code
- PVC cement & primer
- Wire cutter/stripper
- screwdriver ( phillips and flat blade)
- wire nuts

Normally the existing breaker box in the home electrical service or in the pool equipment panel has an available breaker space. If not then you will need to install a new electrical breaker panel or fuse box.

### 3.2 Optional Tools/ Materials

- 3/4 “ vinyl tubing for hose-barb condensation drain fitting in base pan
- Disconnect switch box (if breaker not within site and local codes require)
- PVC Unions or flexible couplings

### 3.3 Helpful Hints

**IMPORTANT: ALLOW AT LEAST 6 INCHES OF STRAIGHT PVC PIPE GOING INTO AND OUT OF THE HEAT EXCHANGER. OTHERWISE ELBOWS OR PVC COUPLINGS WILL PREVENT BACK PANEL REMOVAL AND STOP SERVICE ACCESS INSIDE THE UNIT .THIS WILL ALSO MAKE REPAIR OF ANY PLUMBING PROBLEMS VERY DIFFICULT AND MAY REQUIRE UNNECESSARY HEAT EXCHANGER REPLACEMENT SINCE THESE ARE PERMANENT GLUE JOINT FITTINGS.**

The following is a short list of suggestions which may prove time and money saving to the installer not only during installation but throughout the life of the Heat Siphon®:

1. Installation of PVC unions or hose clamp type flexible couplings at the Heat Siphon® water inlet and outlet lines is recommended to

# HEAT SIPHON® Technical Manual

permit easy removal of the front panel if necessary for future service. ALLOW AT LEAST 6 INCHES OF STRAIGHT PIPE IN AND OUT OF THE UNIT BEFORE INSTALLING UNIONS.

2. Rigid PVC piping entering and leaving the Heat Siphon® SHOULD NOT BE IN A STRAINED OR BOWED POSITION. Higher temperatures of the heated water can soften the PVC where solvent was applied (until it is completely cured) and over time may cause glue joints to break open or leak.

3. Provide a means of draining the pool or spa water for winterizing. Unions are an excellent way to provide drainage as well as easy service access. Draining the Heat Siphon® is recommend any time freezing temperatures are expected while the pool pump is off and no water is circulating.

4. Cut and fit all PVC pipe before any gluing is started. Use generous amounts of PVC cement and twist each glue joint at assembly to ensure freedom from leaks. Don't disturb a joint while the solvent is setting up.

5. If hard conduit is used to provide the electrical supply wiring, then terminate it with several feet of flexible weatherproof conduit (such as sealtite) before entry to the Heat Siphon® junction box. This will allow back panel removal without unwiring the unit in the event future service is required.

6. Minimize the number of elbows used as this increases the pressure drop and pump back pressure.

7. Avoid installing the unit in locations where fences, decks or other structures that can cause air recirculation may be added later and caution the pool owner to avoid such additions in the future.

8. Take the time to explain your installation to the pool owner and help fill out and send in the warranty card. A little consumer education goes a long way to eliminate unnecessary service calls after you've done a proper installation.

## 3.4 Final Plumbing into Pool or Spa

The dual socket water ports allow you to glue either 1.5 inch or 2 inch (with a PVC 2" coupling) schedule 40 PVC pipe directly into the heat exchanger



**IMPORTANT: ALLOW AT LEAST 6 INCHES OF STRAIGHT PIPE BETWEEN THE HEAT EXCHANGER AND ANY COUPLINGS OR ELBOWS TO ALLOW BACKPANEL REMOVAL**



# HEAT SIPHON® Installer

## FOR SERVICING .

**NOTE. If the VERTICAL DISTANCE between the pool water level and the Heat Siphon® is excessive (below or above 2 to 3 feet) your Heat Siphon® may require adjustment of the water flow switch at installation (see initial start up section).**

Because of Heat Siphon's exclusive FULL FLOW Titanium heat exchanger, it requires NO SPECIAL PLUMBING arrangement and should be considered as just another length of PVC pipe in your pool filtration system.

**LOCATION:** Connect Heat Siphon® in the pool pump discharge (return) line DOWNSTREAM of all filters and pool pumps, and UPSTREAM of any electrator chlorinators or chemical pumps.

**SIZE:** All Heat Siphon®'s have 1.5" x 2" fittings for connection to the pool or spa filtration piping. The in-line water pressure drop produced by Heat Siphon is so low (less than 1 1/2 psi at 30 GPM) that as far as the pool pump is concerned the Heat Siphon® can be considered equivalent to a few more feet of PVC pipe.

**NOTE: THE HEAT SIPHON® REQUIRE NO BYPASS PIPING and NO SPECIAL Setting of FLOW RATES as long as a minimum of about 30 GPM is maintained. Only on larger systems where 2" PVC and 2.5 HP and larger pumps are used should a bypass be considered.**

## 3.5 Final Wiring to the Power Line

TO COMPLETE WIRING remove the small gasketed Heat Siphon® junction box cover in the upper right corner of the front panel. Feed the wires into the junction box, complete splicing with wire nuts and replace the cover.

**CAUTION:** Make sure the incoming ground wire is spliced to the Heat Siphon® lead wire marked with the green tape or green insulation and that the unit is bonded to a local earth ground.

# HEAT SIPHON® Technical Manual

## 4.0 Initial Start-up

Please read completely through this section BEFORE STARTING UNIT.

IMPORTANT: Heat Siphon® is equipped with a five minute built in solid state restart delay included to protect control circuit components and to eliminate restart cycling and contactor chatter. This time delay will automatically restart the unit approximately 5 minutes after each control circuit interruption.

### 4.1 Initial Performance Checks

After installation is completed and the unit is ready to start, follow these steps:

1. Turn the Heat Siphon ® thermostat knob completely clockwise
2. Turn on your filter pump, check for leaks and verify flow to and from the pool.
3. Turn on the electrical power supply to the Heat Siphon® . The unit should start immediately.

Note : Even a brief power interruption will activate the solid state 5 minute restart delay and prevent your Heat Siphon from starting until the count down is completed. A power interruption during the delay period will have no effect on the 5 minute countdown.

4. After running a few minutes make sure the air leaving the unit is between 5 to 10 degree F cooler than ambient air - if not call dealer
5. With Heat Siphon® operating, turn the filter pump off. Heat Siphon® should also turn off automatically - if not readjustment of flow switch is Req'd. (See below)
6. Restart the pump/filter. The Heat Siphon ® should start right up - if not readjustment of flow switch req'd. (See below)
7. Allow the Heat Siphon® and pool pump to run 24 hours per day until desired pool water temperature is reached. At this point, slowly turn the thermostat knob counter clockwise until the unit just shuts off and note the number on the dial. Your Heat Siphon& will now automatically restart (as long as your pool pump is running) when the pool temperature drops more than 1.5 °F below the set temperature.

**In other words “set it and forget it.”**

### 4.2 Adjustment of the Water Pressure Switch

Only one Heat Siphon® adjustment may be required at installation. On some models of the Heat Siphon® a gas heater type water pressure sensing switch is used to detect flow

# HEAT SIPHON® Installer

rather than direct flow measurement. The switch prevents Heat Siphon® operation with no water flow. Adjustment is required when the vertical distance from the pool surface to the Heat Siphon® thermostat knob is more than a few feet above or below pool level . To correct this condition, **DISCONNECT ALL ELECTRICAL POWER**. Remove the knob and cover to the control box and adjust the switch as follows.

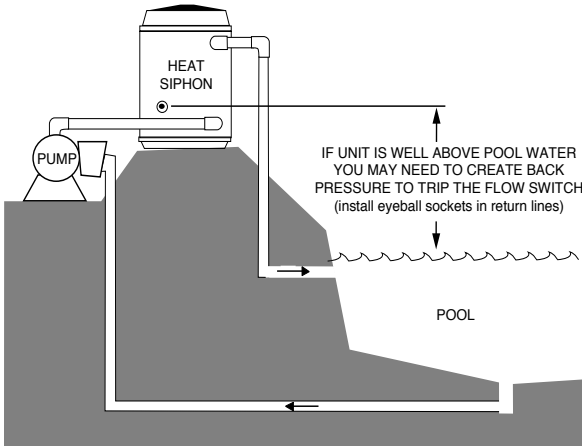

1. If the pool is **BELOW** the unit and the Heat Siphon® won't turn on with the pool pump, turn the pressure switch adjustment thumb wheel to the right until the top of the switch is at the **MINIMUM SETTING (1 psi)**.

If the unit still doesn't start and it is more than 2 feet from the water surface to the thermostat knob then the height difference may be creating a siphoning effect as the pool water returns to the pool, which in turn lowers the pool return line pressure below the minimum trip pressure of this switch. In this case you may need to create sufficient back pressure by using eyeball sockets in all the return lines or by restricting the flow with a reducing fitting downstream of the Heat Siphon®.

# HEAT SIPHON® Technical Manual

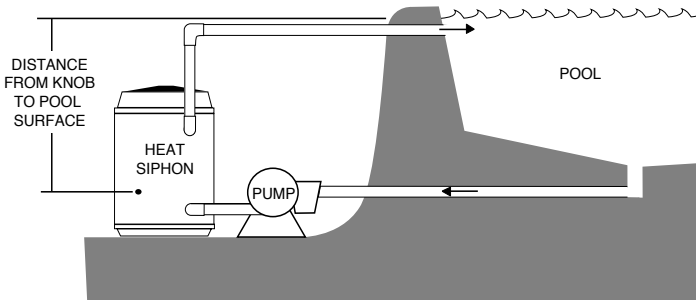

2. If the pool surface is ABOVE the unit and the Heat Siphon® won't turn off when the pool pump shuts off, then measure the vertical distance in feet from the Heat Siphon knob and the pool water surface and divide by 2. This will be the approximate pressure setting required for proper operation. Turn the pressure switch thumb wheel until the top of the wheel lines up with the proper psi lines.

3. Replace cover and repeat the start up/ shut down test above. / shut down test above.

NOTE: WIRES & WATER HOSE NOT SHOWN FOR CLARITY

Fig 4-1a New Style Water Pressure Switch

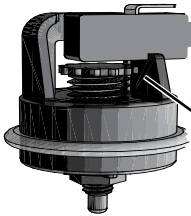

ADJUSTING  
WHEEL  
LOCATION

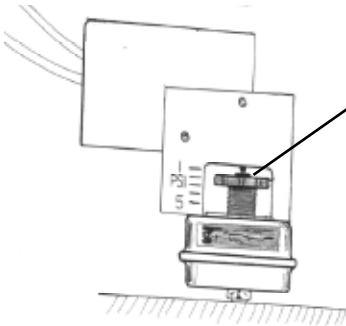

Fig 4-1b Old Style Water Pressure Switch

# HEAT SIPHON® Installer

Figure 4.2 - Water Pressure Switch Location in Control Box

